

technical sheet

standard single lifting beams

Applications

Lifting of various loads.

Description

Range of lifting beams with fixed or adjustable load-centre distance fitted with 2 lower attachment components.

Each lower attachment point allows a shackle to be attached to which lifting accessories can be fitted.

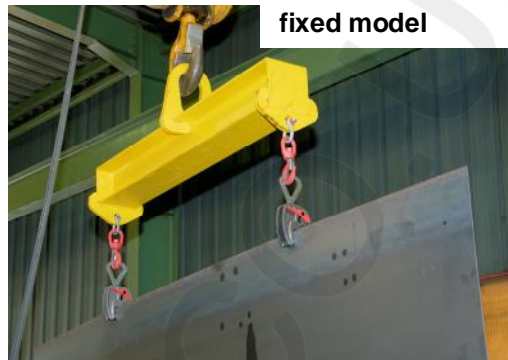

Adjustable model : securing of lower attachment points between two steel locking components is simple and sure. The adjustment -with step of 100 mm- is easily made by moving the lower pieces along the beam.

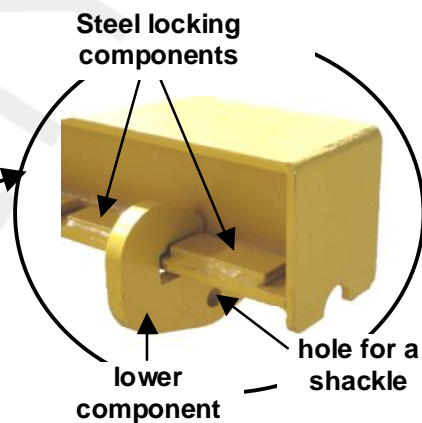

Functioning

Install necessary accessories on the lifting beam ensuring that these accessories meet all the lifting beam use conditions (see page 3).

Attach the lifting beam to the lifting means.

Adjustable model only: adjust both lower points -taking the load geometry into account- sliding them onto the profile. Securely position the adjustable attachment points between appropriate steel locking components.

Hang the load on the lifting beam and perform lifting.

Ensure that the load is evenly balanced: the lifting beam must be horizontal during lifting (see Diagram 1) and efforts on axle direction of lower points vertical (see Diagram 2). Otherwise, stop the lifting and correctly position the load, the lifting beam and accessories.

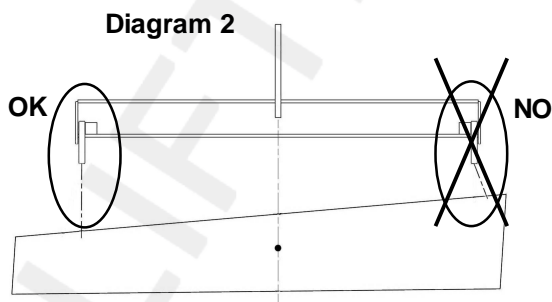

COG : centre of gravity of the load.

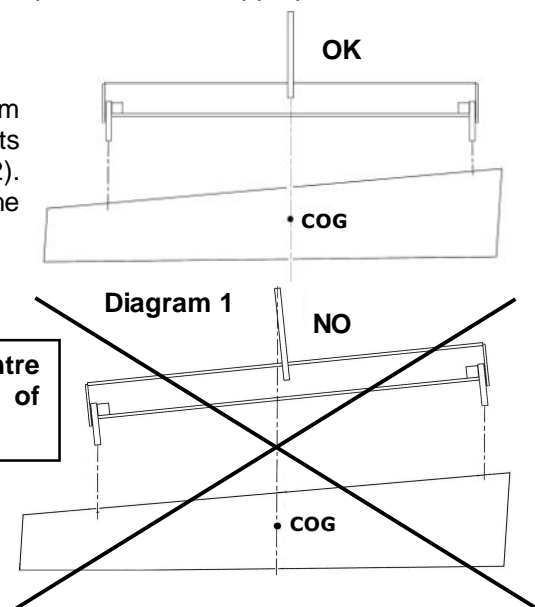

technical sheet

standard single lifting beams

General characteristics

- Manufactured without load bearing welds.
- Hot epoxy coating.
- Designed and manufactured in accordance with the EN 13155.2003 norm.
- Product with EC marking and delivered with a declaration of conformity and instructions for use.

Dimensional characteristics (see Diagrams page 3)

WLL (t)	L (m)	L min ⁽¹⁾ (m)	A	B	C	D	E	F	G	H	Overall dimensions Height x Width x Length	Weight (kg)	Accessories (WLL & references)			
													HR shackles ⁽³⁾		Hooks ⁽³⁾	
													Fixed model	Adjustable model	Fixed model	Adjustable model
1	1	0,4	100	150	20	15	15	20	15	310	360 x 180 x 1050	26	1t (C036H)		0,8t (C120E)	
	2	1	100	150	20	15	15	20	15	310	360 x 180 x 2050	43	1t (C036H)		0,8t (C120E)	
	3	1	100	150	20	15	15	20	15	310	360 x 180 x 3050	59	1t (C036H)		0,8t (C120E)	
	4	2	100	150	20	20	20	20	15	320	380 x 200 x 4050	93	1t (C036H)		0,8t (C120E)	
	5	2	100	150	20	15	15	21	15	370	420 x 240 x 5050	167	1t (C036H)		0,8t (C120E)	
2	1	0,4	100	150	20	15	15	20	15	310	360 x 180 x 1050	26	1,5t (C037H)		1,5t (C125E)	
	2	1	100	150	20	20	20	20	15	320	380 x 200 x 2050	53	1,5t (C037H)		1,5t (C125E)	
	3	1	100	150	20	15	15	21	15	370	420 x 240 x 3050	106	1,5t (C037H)		1,5t (C125E)	
	4	2	100	150	20	15	15	21	15	370	420 x 240 x 4050	137	1,5t (C037H)		1,5t (C125E)	
	5	2	100	150	20	20	20	27	15	390	450 x 260 x 5050	198	1,5t (C037H)		1,5t (C125E)	
3	1	0,4	100	150	20	20	20	20	15	320	380 x 200 x 1050	33	1,5t ⁽²⁾ (C037H)	3,25t ⁽¹⁾ C039H	1,5t ⁽²⁾ (C125E)	2,5t ⁽¹⁾ C126E
	2	1	100	165	20	15 ⁽²⁾ 20 ⁽¹⁾	20	21 ⁽²⁾ 27 ⁽¹⁾	15 ⁽²⁾ 20 ⁽¹⁾	380	370 x 240 x 2060	83	1,5t ⁽²⁾ (C037H)	3,25t ⁽¹⁾ C039H	1,5t ⁽²⁾ (C125E)	2,5t ⁽¹⁾ C126E
	3	1	100	165	20	15 ⁽²⁾ 20 ⁽¹⁾	20	21 ⁽²⁾ 27 ⁽¹⁾	20 ⁽²⁾ 15 ⁽¹⁾	380	370 x 240 x 3060	113	1,5t ⁽²⁾ (C037H)	3,25t ⁽¹⁾ C039H	1,5t ⁽²⁾ (C125E)	2,5t ⁽¹⁾ C126E
	4	2	100	150	20	20	20	27	15	390	450 x 260 x 4050	162	1,5t ⁽²⁾ (C037H)	3,25t ⁽¹⁾ C039H	1,5t ⁽²⁾ (C125E)	2,5t ⁽¹⁾ C126E
	5	2	100	165	20	20	20	27	20	400	470 x 280 x 5060	240	3,25t (C039H)		2,5t (C126E)	
4	1	0,4	100	165	20	20	20	27	20	380	370 x 240 x 1060	52	3,25t (C039H)		3,2t (C127E)	
	2	1	100	165	20	20	20	27	20	380	370 x 240 x 2060	83	3,25t (C039H)		3,2t (C127E)	
	3	1	120	200	20	20 ⁽²⁾ 25 ⁽¹⁾	25	27 ⁽²⁾ 32 ⁽¹⁾	15 ⁽²⁾ 25 ⁽¹⁾	450	510 x 260 x 3070	140	3,25t (C039H)		3,2t (C127E)	
	4	2	100	165	20	20	20	27	20	400	470 x 280 x 4060	197	3,25t (C039H)		3,2t (C127E)	
	5	2	120	200	20	25	25	32	25	480	540 x 300 x 5070	295	3,25t (C039H)		3,2t (C127E)	
5	1	0,4	120	200	20	25	25	32	25	450	510 x 260 x 1070	68	3,25t ⁽²⁾ C039H	4,75t ⁽¹⁾ (C040H)	3,2t ⁽²⁾ C127E	5,4t (C128E)
	2	1	120	200	20	25	25	32	25	450	510 x 260 x 2070	104	3,25t ⁽²⁾ C039H	4,75t ⁽¹⁾ (C040H)	3,2t ⁽²⁾ C127E	5,4t (C128E)
	3	1	120	200	25	20 ⁽²⁾ 25 ⁽¹⁾	25	27 ⁽²⁾ 32 ⁽¹⁾	20 ⁽²⁾ 25 ⁽¹⁾	450	520 x 280 x 3070	165	3,25t ⁽²⁾ C039H	4,75t ⁽¹⁾ (C040H)	3,2t ⁽²⁾ C127E	5,4t (C128E)
	4	2	120	200	20	25	25	32	25	480	540 x 300 x 4070	244	3,25t ⁽²⁾ C039H	4,75t ⁽¹⁾ (C040H)	3,2t ⁽²⁾ C127E	5,4t (C128E)
	5	2	120	200	20	25	25	32	25	500	570 x 320 x 5070	348	3,25t ⁽²⁾ C039H	4,75t ⁽¹⁾ (C040H)	3,2t ⁽²⁾ C127E	5,4t (C128E)
6	1	0,4	120	200	20	25	25	32	25	450	510 x 260 x 1070	69	4,75t (C040H)		5,4t (C128E)	
	2	1	120	200	25	25	25	30	25	450	520 x 280 x 2070	123	4,75t (C040H)		5,4t (C128E)	
	3	1	120	200	20	25	25	32	25	480	540 x 300 x 3070	194	4,75t (C040H)		5,4t (C128E)	
	4	2	120	200	20	25	25	32	25	500	570 x 320 x 4070	288	4,75t (C040H)		5,4t (C128E)	
	5	2	120	200	20	25	25	32	25	530	600 x 340 x 5070	392	4,75t (C040H)		5,4t (C128E)	

WLL : Working Load Limit

(1) for adjustable models only / (2) for fixed models only / (3) shackles and swivel hooks proposed as options

The shackles are essential for the assembly of hooks on the lower points of the lifting beam.

dimensions in mm

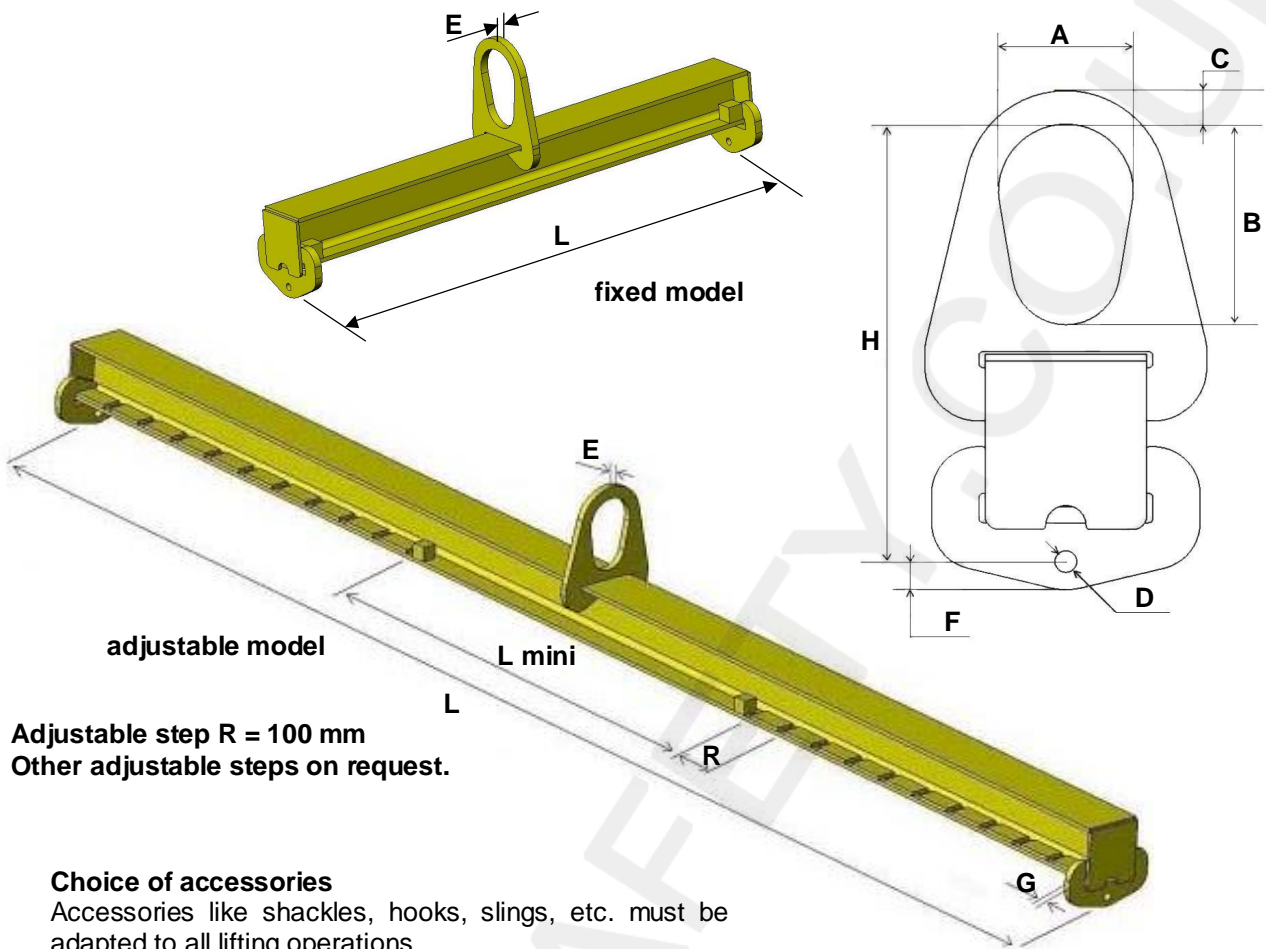

Adjustable step R = 100 mm
Other adjustable steps on request.

Choice of accessories

Accessories like shackles, hooks, slings, etc. must be adapted to all lifting operations.
For adjustable lifting beams, following example is the most critical:

$$F1 = F * L \text{ mini} / (L + L \text{ mini})$$

$$F2 = F * L / (L + L \text{ mini})$$

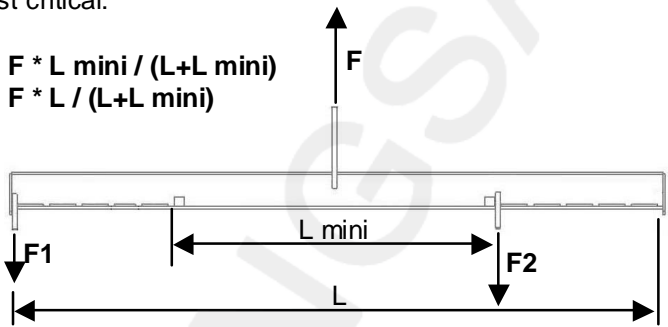

Example : for a lifting beam with capacity of 3 t, adjustable centre distance from 1 to 2 m :
L min = 1, L = 2 and F = 3
Then F1 = 1 t and F2 = 2 t
Installed accessories must be designed for a minimum capacity of 2t.

Important instructions

- Do not use for personnel lifting.
- Strictly forbidden to either be under or walk under the load
- Working temperature: -20° to +100°C.
- Accessories must be adapted to all lifting operation conditions.
- For all lifting operations, make sure that the load itself can withstand the bending stresses and deformations it is likely to be subjected to during the lifting operation.
- Never lift loads which have non-attached charges on top.
- Never exceed Working Load Limit of the equipment (W.L.L. – see engraving).
- The weight of the lifting beam, added to the weight of the load lifted, must be less than the capacity of the lifting appliance.
- Never mount more than one element in the hole of each lower point of the lifting beam.