

SELBY ENGINEERING AND LIFTING SAFETY LTD. TEL: +44 (0) 1977 684 600



I.R.E.P S.A.S
59450 Sin le Noble - France
Tel.: +33 (0) 27 93 08 08
Fax: +33 (0) 27 93 08 00

Copyright © 2008. Ingersoll-Rand Company
All Rights reserved.

LIFTCHAIN LC2A Series Model LC2A120D... Trolley Mount 12 Tons Lifting capacity

IREP Drawing Number	Rev.
08/04/30-L645	A
Customer Drawing Number	
Folio :	1/1
Engineering Mgr. Approval : JLF	

Standard Features :

- Rugged and Compact modular design
- Design temperature -20°C
- Explosion proof - 100% duty rating - No downtime
- Gear type air hoist motor with high starting torque providing long life
- Variable speed control at pilot pendant (4 buttons)
- Top and bottom limit switches intergrated in hoist body for better protection
- Automatic fail safe disc brake (no adjustment required) on hoist and trolley motor
- Zinc plated load chain for corrosion resistance
- Exhaust muffler for quiet operation
- Sound pressure level < 84 dBA
- Low maintenance cost
- Individually load tested before shipment

*It is strongly recommended to use a lubricating and a filtration system on the compressed air line.
The compressed air temperature must not exceed 65°C at the motor air inlet.
For higher temperature, please consult us.*

Options:

- Overload protection device adjusted at factory during load tests
- Main air emergency stop at pendant as per EN 418
- Spark resistant package for ATEX zone 1
- Chain containers
- Marine or offshore paint including sandblasting
- Mining versions and hydraulic versions available

Ex classifications (ATEX)

- Standard version is suitable for Zone 2 (ATEX Marking Ex II 3 GD c IIB 135°C x)
- Optional spark resistant package is suitable for Zone 1 (ATEX marking Ex II 2 GDc IIB135°Cx)

FEM classification

- Driving mechanism classification 1Bm

Built in ISO 9001 certified factory

Technical data at 6.3 bar

Model	LC2A120D
Rated Capacity (metricTon)	12
Falls of chain	2
Lifting speed at rated load (m/min)	1.1
Lifting speed at no load (m/min)	1.8
Lowering speed at rated load (m/min)	1.3
Travelling Speed at rated load (m/min)	12
Travelling Speed at no load (m/min)	15
Working pressure range (Bar)	4 to 7
Hoist air consumption at rated load (m ³ /min)	5
Trolley motor air consumption (m ³ /min)	1.9
Mini-Maxi Trolley flange adjustment (mm)	130-310
Minimum headroom (mm)	995
Minimum curve radius (m)	3
Air inlet (BSP)	3/4
Chain size (mm)	16x45
*Weight with std lift (Kg)	335
Chain Weight per meter of lift (kg)	11.4

Net weight is given with standard lift of 3m and standard control length of 2m

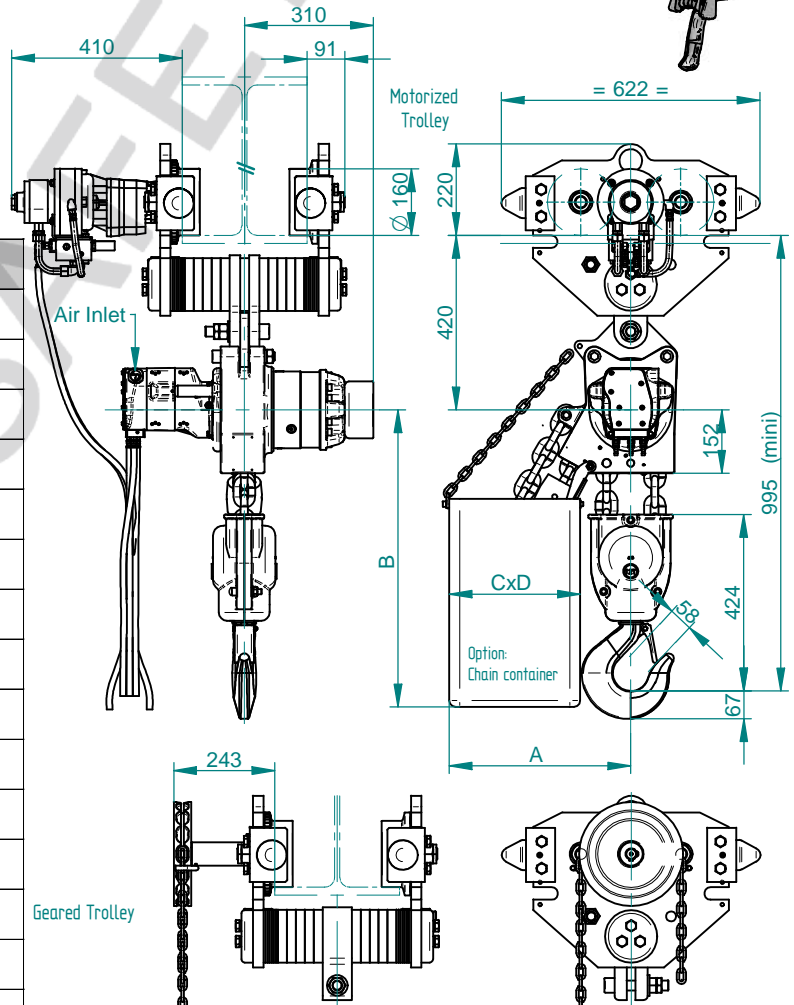
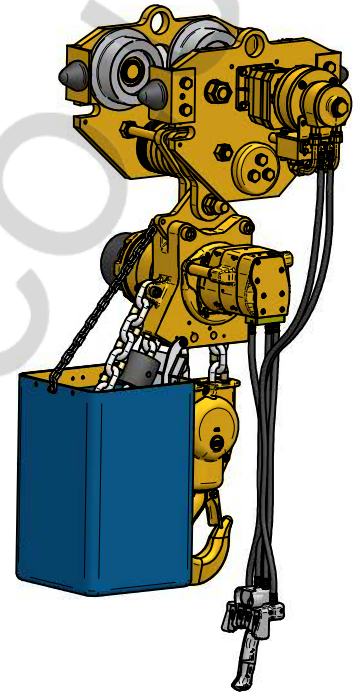

Chain container dimensions (mm)

Height of lift	A	B	CxD	Option code
6 m	437	715	315x315	A
13 m	527	915	400x400	B
20 m	527	915	550x400	C

The equipment described on this sheet is subject to the general sales and warranty conditions of Ingersoll-Rand company. Because of the constant evolution of technology, Ingersoll-Rand company reserves the right to modify without notice the specifications contained in this document.