



LIFTINGSAFETY

SELBY ENGINEERING AND LIFTING SAFETY LTD

Tel: +44 (0) 1977 684 600 Email: sales@liftingsafety.co.uk

LIFTING EQUIPMENT AND HEIGHT SAFETY SPECIALISTS

Lifting davit SD125 – 250 – 500 ..



3 LINCOLN WAY, SHERBURN-IN-ELMET, LEEDS, WEST YORKSHIRE, UK, LS25 6PJ

Registered in England No: 3013233

V.A.T. Reg No: 599 2962 66

Web: www.liftingsafety.co.uk

Email: sales@liftingsafety.co.uk





GB

1. Introduction

Dear client,

Thank you for having made your choice, you have chosen a professional hoisting product which has been developed, produced and tested with the greatest of care.

However, it is our duty to draw your attention to the fact that firstly, it is essential to read these instructions for use carefully and then to execute them before the product is actually put to use.

2. Safety Precautions



The lifting davits, type SD are hand-driven by means of a cable winch.

The winches are only to be used for the lifting of goods. Transport (lifting) of persons as well as their being located under a moving load is not permissible.

The winches have a static safety factor of 4, the Davit has a safety factor of 1,5.

The winches are not suitable for:

- mechanized drive
- continuous use
- use in an area in which aggressive and/or explosive substances are used.

Technical alterations and/or the attachment of marginal devices to the winches are permitted only with the manufacturer's written consent.

Servicing, mounting, possible repairs and the winch maintenance are permitted only by specialized persons who:

- have been appointed and authorized
- have been trained
- are familiar with the correct regulations
- always use original parts for repairs

2.1. Winch



The winch is equipped with a load pressure brake which holds the load at any required height and ensures that it undergoes controlled lowering.

The load pressure brake must not be greased or oiled. This destroys the brake function!

The stipulated hoisting capacity calculated on the first cable layer, stated on the type identity sticker must not be exceeded.



The winch must at least be mounted with the required mounting materials from chart 1.

Never touch moving parts during use!

Always run the following check before use:

- brake function
- quality of the cable and hoisting parts
- carrier construction

The winch must be tested by a professional at least once a year.

2.2. Load

Pay attention to the following with respect to the load:

- never leave the load unattended whilst elevated
- do not allow the load to sway
- never allow the load to fall abruptly from the cable
- ensure that the hoisting height remains in clear view



LIFTING SAFETY

SELBY ENGINEERING AND LIFTING SAFETY LTD

Tel: +44 (0) 1977 684 600 Email: sales@liftingsafety.co.uk

LIFTING EQUIPMENT AND HEIGHT SAFETY SPECIALISTS

2.3. Cable and hoisting material(s)

Pay attention to the following with respect to the cable and hoisting material(s):



- only use DIN 15020 certified cables with the minimum required breaking force from chart 1 and 2.
- cables and load hook must be regularly checked and maintained according to DIN 15020
- the sideways leverage angle, the lanyard, must not exceed 3 degrees
- **there must be a minimum 3 safety windings on the first layer of the drum when loaded**
- the top of the last cable layer must have 1 1/2 x the cable diameter clearance between the outer edge of the drum flange



- the cable must be prestressed when being wrapped around the drum
- **never reach into the cable assembly**
- only grasp hold of the cable when wearing safety gloves
- adhere to the correct cable capacity
- loading hooks must be fitted with safety catches



safety catch

- according to the regulations loading hooks must be mounted to the cable with a thimble and a talurit clamp
- the load must be mounted correctly



3. Technical details

The type designation is as follows:

SD = lifting davit suitable for lifting a load 125, 250 or 500kg

GR= painted grey colour

EV= zinc-plated

Chart 1

| Type SD125 – 250 – 500 | | SD125 | SD250 | SD500 |
|---|-----|---------------|-------|-------|
| Hoisting load first layer | Kg | 125 | 250 | 500 |
| Hoisting load last layer | Kg | 125 | 250 | 268 |
| Cable diameter | mm | 4 | 4 | 5 |
| Min. breaking force of cable | kN | 9 | 9 | 15 |
| Max. Cable storage calculated per cable compartment | m | 24 | 24 | 14 |
| Max. cable layers per cable compartment | | 8 | 8 | 6 |
| Crank force first layer | daN | 10 | 10 | 10 |
| Transmission ratio | | 1:7,9 | 1:7,9 | 1:7,9 |
| Hoisting height per crank rev. | mm | 20 | 20 | 20 |
| Own weight | Kg | 25 | 25 | 25 |
| Floor fastening ON, class 8.8 bolts | | 4xM20 | | |
| Permitted environment temperature | | -20°C / +40°C | | |

3 LINCOLN WAY, SHERBURN-IN-ELMET, LEEDS, WEST YORKSHIRE, UK, LS25 6PJ

Registered in England No: 3013233

Web: www.liftingsafety.co.uk

V.A.T. Reg No: 599 2962 66

Email: sales@liftingsafety.co.uk





LIFTINGSAFETY

SELBY ENGINEERING AND LIFTING SAFETY LTD

Tel: +44 (0) 1977 684 600 Email: sales@liftingsafety.co.uk

LIFTING EQUIPMENT AND HEIGHT SAFETY SPECIALISTS

Dimensions

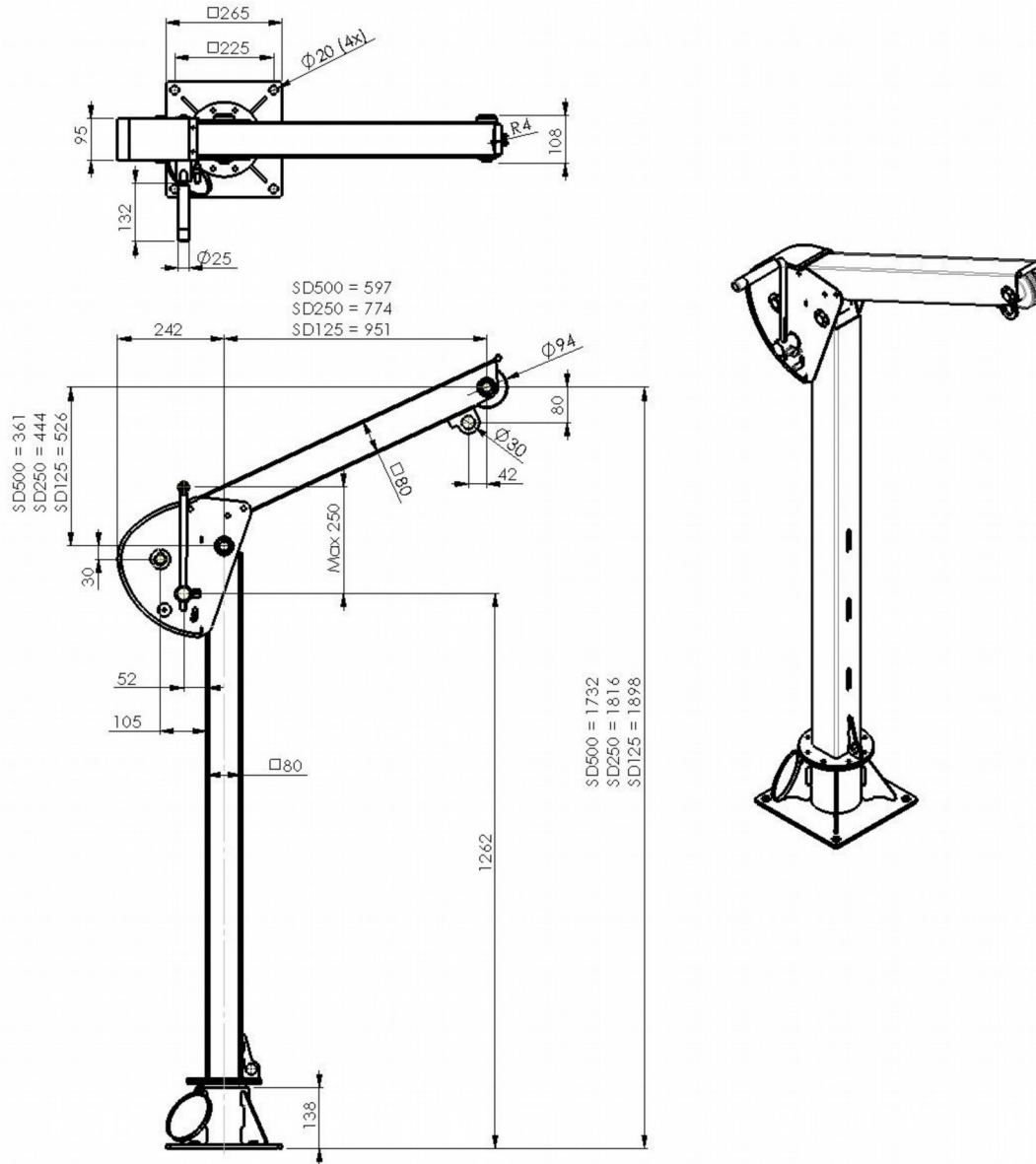

3.1. Job description

The hoisting davit has been designed for hoisting goods on location, with a maximum total hoisting capacity of 500 kg in the first cable layer.

This foldable hoisting davit helps you carry out your work effectively without risk of physical overload, according to the latest health and safety act. Its weight is less than 25 kg so that one person can move the hoisting davit to the necessary location. The hoisting davit is ready for use within 5 seconds by means of the folding system of the boom.

The construction exists mainly of construction steel finished with a 2 component lacquer coating or an electrolytic zinc coating. The winch consists of a drum winch with a gear transmission with a self-braking capacity. This self-braking capacity ensures a hold of the load at any required height during hoisting and lowering. All rotating parts run in maintenance free bearings. The pole is provided with a pivot bearing which enables swivelling the davit 360°. The crank is adjustable in length and removable.

3 LINCOLN WAY, SHERBURN-IN-ELMET, LEEDS, WEST YORKSHIRE, UK, LS25 6PJ

Registered in England No: 3013233

Web: www.liftingsafety.co.uk

V.A.T. Reg No: 599 2962 66

Email: sales@liftingsafety.co.uk





3.2. Assembly instructions hoisting davit

In order to use the hoisting davit in a safe and responsible manner a floor socket has been developed. By placing the lifting davit herein, the hoisting davit is stable and ready for use. The floor socket can be installed everywhere by means of chemical anchors or standard fixing bolts.

Always check the floor socket, the pole, boom and winch on dimensions, dirt, damage or deformation. If necessary, clean and replace the damaged parts.

Remove the lid from the floor socket and place the pole into the floor socket. Check the stability after mounting.

Release the cable by turning the crank counter clockwise. Disassemble the load hook from the hole at the bottom of the pole. Now it is possible to fold out the boom upwards.



3.3 Disassembly instructions hoisting davit

Mind the hoisting davit is free from any load.
Turn the cable inside until the hook is hanging about half a meter below the roller. Then lift the boom somewhat upwards.



Push the red pin upwards, mind the boom being kept supported. Lower the boom gently until the load hook hits the stand.

Mount the hook into the hole of the pole. Stress the cable by turning the crank clockwise.

Now the hoisting davit can be removed from the floor socket.
Shut the lid of the floor socket in order to prevent soiling!



3.4 Cable mounting

To choose the right cable chart 1 must be consulted.

Mind the hoisting davit standing unfolded in the floor socket.

Disassemble the protective cover of the hoisting davit. This cover is secured by means of four M6 hexagon screws.

Put the hook less end of the cable through the upper groove of the roller; let the cable slide through the boom until the cable end finds itself near the cable drum.

On the hoisting davit the cable is secured through the 8 mm hole in the cable drum. Then it is possible to secure the cable by means of a M8 adjuster screw with cup point.





LIFTING SAFETY

SELBY ENGINEERING AND LIFTING SAFETY LTD
Tel: +44 (0) 1977 684 600 Email: sales@liftingsafety.co.uk
LIFTING EQUIPMENT AND HEIGHT SAFETY SPECIALISTS



Attention!

The brake does not work in the case of an incorrect cable run-off.

There must be a minimum of 3 safety windings on the first layer of the drum when loaded.

Now the cable can be wrapped around the drum. The cable must be prestressed when being wrapped around the drum. When reeling the cable please check if the cable is wrapping itself smoothly around the drum. If this process is running well, the cable can be reeled around the drum until the hook is hanging about 15 cm below the roller.

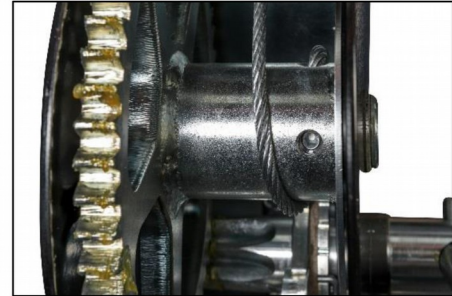

The protective cover can be reassembled again by means of the four M6 hexagon screws.

3.5. Operating

The winches are suitable for manual operation only.
For the load to be hoisted, turn the crank clockwise.
For the load to be lowered, turn the crank anticlockwise.

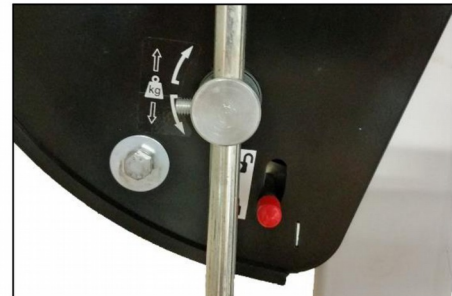

4. Maintenance



The winch must be unloaded for inspection and maintenance tasks.

Inspection and maintenance tasks must be performed by skilled personnel, e.g. via your Gebuwin dealer.

| Inspection/ Maintenance interval | Tasks |
|----------------------------------|--|
| Before each use | <ul style="list-style-type: none"> - visually check cable and loading hook - check amount of grease* on the gearing - check the brake function |
| Per quarter | <ul style="list-style-type: none"> - visually check cable and loading hook for any fracture - grease the gearing - check the load pressure brake for wear and tear <p>Replace the brake discs as needed</p> <p>Be careful: Do not get any grease on the brake discs or preceding surfaces</p> |
| Annually | <ul style="list-style-type: none"> - check the cable according to DIN 15020 pg. 2 for wear and tear; also test and maintain the minimum breaking force. - check the tightness of the mounting bolts - check all parts of the lifting davit on wear and if necessary replace and grease. - check the flange thickness (minimum 4 mm) of the plastic cable pulleys. Replace them if necessary. - check the diameters of the floor cover, thorn and boom as indicated in section 3.2. - check the type identity sticker for clarity |

* Texaco "Texclad premium 2" is recommended by us for the gearing (or equivalent).

3 LINCOLN WAY, SHERBURN-IN-ELMET, LEEDS, WEST YORKSHIRE, UK, LS25 6PJ

Registered in England No: 3013233

V.A.T. Reg No: 599 2962 66

Web: www.liftingsafety.co.uk

Email: sales@liftingsafety.co.uk





LIFTING SAFETY

SELBY ENGINEERING AND LIFTING SAFETY LTD

Tel: +44 (0) 1977 684 600 Email: sales@liftingsafety.co.uk

LIFTING EQUIPMENT AND HEIGHT SAFETY SPECIALISTS

5. Troubleshooting

| Trouble/Malfunction | Cause | Solution |
|--|---|---|
| The unloaded winch rotates heavily | <ul style="list-style-type: none">- no grease on the gearing- dirt on the gearing- during mounting the winch has pulled askew | <ul style="list-style-type: none">- apply grease- clean with a detergent and re-grease- level the mounting surface and re-mount the winch |
| The load cannot be held | <ul style="list-style-type: none">- the cable has been incorrectly wound round the drum which means the crank turning direction is incorrect- the brake discs are either worn down or faulty | <ul style="list-style-type: none">- wind the cable correctly around the drum- check and/or renew the brake discs |
| The load pressure brake does not start to work | <ul style="list-style-type: none">- braking mechanism and/or discs are jammed due to infrequent use | <ul style="list-style-type: none">- loosen the brake by hitting the crank in the correct turning direction with the flat of the hand |
| Hoisting davit rotates heavily | <ul style="list-style-type: none">- pivot bearing in the floor socket is worn-out or filthy | <ul style="list-style-type: none">- clean or replace and re-grease (use the lid to prevent soiling) |

6. Service

For servicing and/or servicing parts contact your nearest Gebuwin dealer.

The exploded view diagram with regard to the servicing parts is available on the internet website:

www.gebuwin.com



Use original servicing parts only; correct functioning cannot otherwise be guaranteed!

7. Environment

At the end of the winch's lifespan, the various winch parts must be disposed of according to the current environmental regulations.

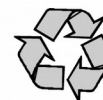

3 LINCOLN WAY, SHERBURN-IN-ELMET, LEEDS, WEST YORKSHIRE, UK, LS25 6PJ

Registered in England No: 3013233

V.A.T. Reg No: 599 2962 66

Web: www.liftingsafety.co.uk

Email: sales@liftingsafety.co.uk

